J1502B - HP Rack System/E25

Technical Data

Product Number
J1502B

Save valuable floor space with the vertically extendible HP Rack System/E

Designed and built to the highest HP quality standards, the Rack System/E delivers leading edge protection in the simplest form. Ease of integration, installation, and use of characterizes this 25U rack that is comprised of:

- 63% Perforated, locking rear door
- Bolt-on front/back anti-tip feet
- Fully perforated top cap
- 3-inch urethane casters
- Leveling feet

Individual racks may be expanded for an additional 8Us of vertical space.

Standards

Conforms to the Electronic Industries Association (EIA) standard 310-D. It is a Type A cabinet with 25U of vertical mounting space. One 'U' is equal to 44.45 mm (1.75 in).

- Ability to move and ship fully integrated racks
- Optimized ventilation with fully perforated top, and rear door
- Extendibility can add 8Us of vertical mounting space
- Easy, bolt-on (front and back) anti-tip feet
- Numbered 12-gauge steel columns for easy installation and secure racking of up to 907 kg (2000 lbs) of equipment
- Columns include threaded inserts (AVKs) at strategic locations for quick installation of common accessories such as the front door and PDUs.

Shipping/Setup

- Shipping cost included in price
- Can fit through most doorways around the world
- Packaging designed for integrated rack shipment
- Self-tuning pallet adjusts for variable integrated rack weights
- Shipping pallet includes ramp for easy set-up



Tools required for setup:

- Torx T25 screwdriver
- Phillips #2 screwdriver
- 13mm Socket wrench

Warranty

- Three year replacement

Features

Specifications

Weight

Rack (empty): 67.13 kg (148 lbs)
Rack (empty) on shipping pallet: 135.17 kg (298 lbs)
Rear door: 15.88 kg (35 lbs)
Anti-tip foot: 16.16 kg (18 lbs)

Supported weight

Load capacity:
 On shipping pallet: 816 kg (1800 lbs);
 Off shipping pallet: 907 kg (2000 lbs)
Casters rating: 453.6 kg (1000 lbs) per caster

Material

Columns: 12-gauge, cold-rolled steel
Base: 10-gauge, cold-rolled steel
Top cap: 18-gauge, cold-rolled steel

Color

Columns and base: Slate gray (6009-0190)
Top: Quartz gray (6009-0242)
Side panels: Quartz gray (6009-0242)
Rear door: Quartz gray (6009-0242)

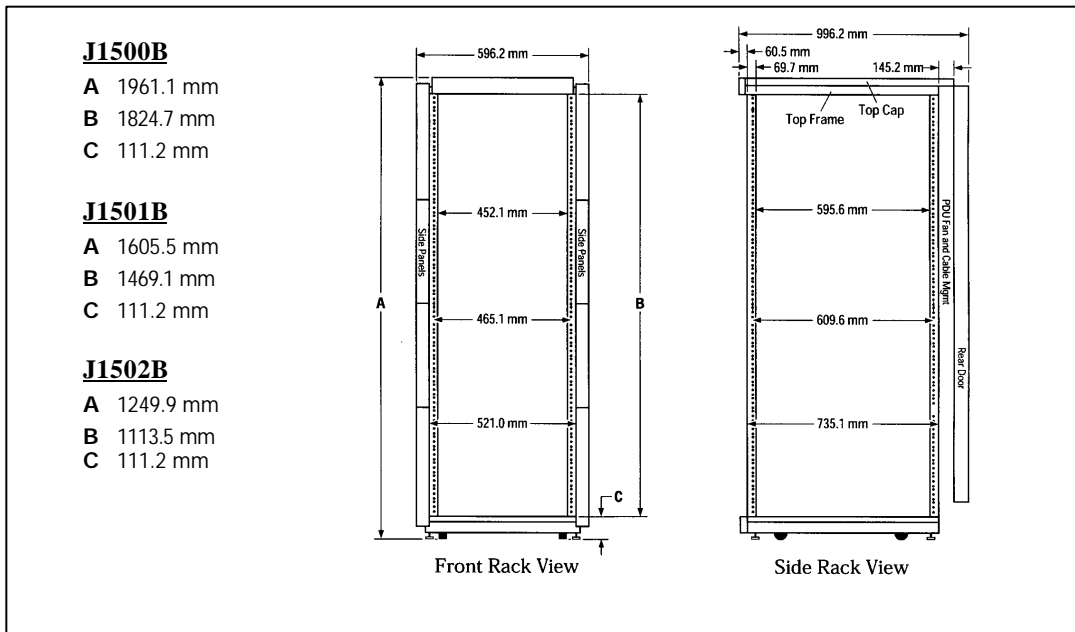

Related Products

This rack is also available in two alternate sizes:

- **J1500B** - 41U of vertical mounting space, includes perforated rear door, bolt-on (front and back) anti-tip feet
- **J1501B** - 31U of vertical mounting space, includes perforated rear door, bolt-on (front and back) anti-tip feet

Optional Accessories

J1471A	Vertical Extension Kit
J1508A	Side Panel Kit (1 kit per rack)
J1511A	Front Door: Perforated, lockable
J1514A	Filler Panels (set of 6, 1 EIA ea)
J1518A	Keyboard Kit, retractable
J1519B	Monitor Kit
J1520A	Plain Shelf, static
J1521A	Lift Hooks (set of 4)
J1522A	Mounting Hardware