

---

# J1500B - HP Rack System/E41

## Technical Data

**Product Number**  
**J1500B**

---

### Save valuable floor space with the vertically extendible HP Rack System/E

Designed and built to the highest HP quality standards, the Rack System/E delivers leading edge protection in the simplest form. Ease of integration, installation, and use of characterizes this 41U rack that is comprised of:

- 63% Perforated, locking rear door
- Bolt-on front/back anti-tip feet
- Numbered columns
- Fully perforated top cap
- 3-inch urethane casters
- Leveling feet

Multiple racks may be tied together to create continuous data center rack space. Individual racks may be expanded an additional 8Us of vertical space.

### Standards

Conforms to the Electronic Industries Association (EIA) standard 310-D. It is a Type A cabinet with 41U of vertical mounting space. One 'U' is equal to 44.45 mm (1.75 in).

### Features

- Ability to move and ship fully integrated racks
- Optimized ventilation with fully perforated top, and rear door
- Extendibility can add 8Us of vertical mounting space
- Easy, bolt-on (front and back) anti-tip feet
- Numbered 12-gauge steel columns for easy installation and secure racking of up to 907 kg (2000 lbs) of equipment
- Columns include threaded inserts (AVKs) at strategic locations for quick installation of common accessories such as the tie kit, front door and PDUs

### Shipping/Setup

- Shipping cost included in price
- Can fit through most doorways around the world
- Packaging designed for integrated rack shipment
- Self-tuning pallet adjusts for variable integrated rack weights
- Shipping pallet includes ramp for easy set-up



Tools required for setup:

- Torx T25 screwdriver
- Phillips #2 screwdriver
- 13mm Socket wrench

### Warranty

Three year replacement

## Specifications

### Weight

**Rack (empty):** 81.65 kg (180 lbs)  
**Rack (empty) on shipping pallet:** 151.95 kg (335 lbs)  
**Rear door:** 23.6 kg (52 lbs)  
**Anti-tip foot:** 8.16 kg (18lbs)

### Material

**Columns:** 12-gauge, cold-rolled steel  
**Base:** 10-gauge, cold-rolled steel  
**Top cap:** 18-gauge, cold-rolled steel

### Supported weight

**Load capacity:**  
 On shipping pallet: 816 kg (1800 lbs);  
 Off shipping pallet: 907 kg (2000 lbs)  
**Casters rating:** 453.6 kg (1000 lbs) per caster

### Color

**Columns and base:** Slate gray (6009-0190)  
**Top:** Quartz gray (6009-0242)  
**Side panels:** Quartz gray (6009-0242)  
**Rear door:** Quartz gray (6009-0242)

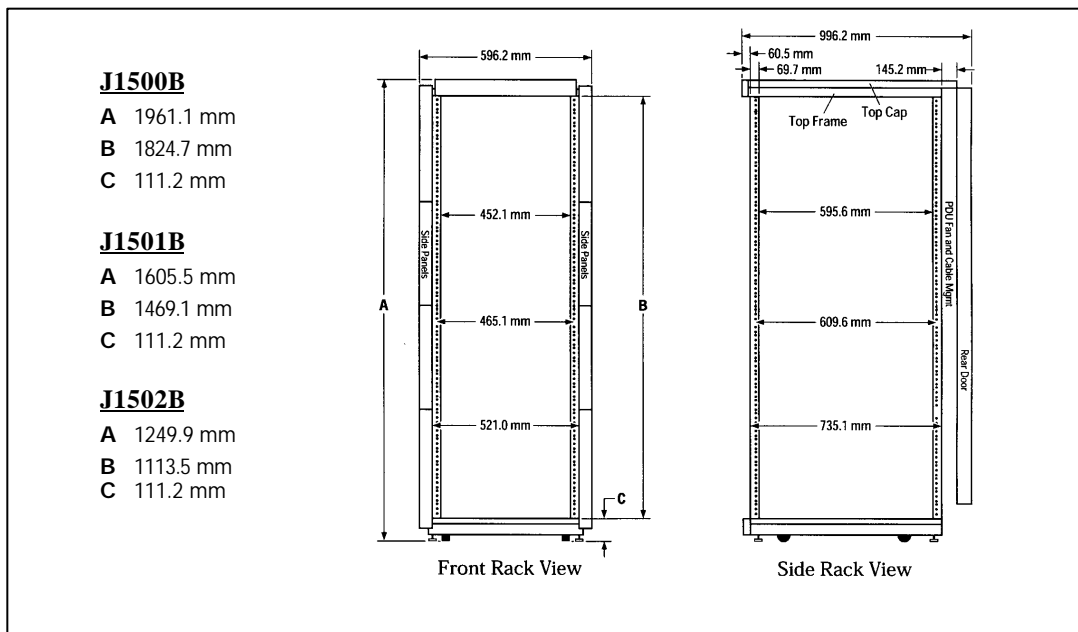

## Related Products

This rack is also available in two alternate sizes:

- **J1501B** - 33U of vertical mounting space, includes perforated rear door, bolt-on (front and back) anti-tip feet
- **J1502B** - 25U of vertical mounting space, includes perforated rear door, bolt-on (front and back) anti-tip feet.

## Optional Accessories

<b>J1471A</b>	Vertical Extension Kit
<b>J1506A</b>	Side Panel Kit (1 kit per rack)
<b>J1509A</b>	Front Door: Perforated, lockable
<b>J1512B</b>	Tie Kit
<b>J1514A</b>	Filler Panels (set of 6)
<b>J1518A</b>	Keyboard Kit, retractable
<b>J1519B</b>	Monitor Kit
<b>J1520A</b>	Plain Shelf, static
<b>J1521A</b>	Lift Hooks (set of 4)
<b>J1522A</b>	Mounting Hardware